

# SCHOOL-SCOUT.DE

Unterrichtsmaterialien in digitaler und in gedruckter Form

## Auszug aus:

*Zahlenraum 0 bis 5 kennenlernen*

Das komplette Material finden Sie hier:

[School-Scout.de](https://school-scout.de)

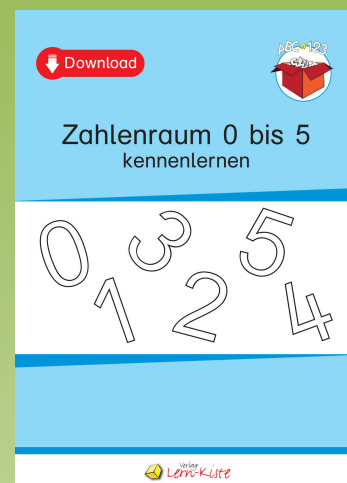

## Informationen zum Material:

Dieses Themenpaket umfasst 90 Seiten. Das Material bietet verschiedene Übungen zu Ziffern und Mengen im Zahlenraum von 0 bis 5 an. Die erste Arbeitseinheit befasst sich mit dem Schreiben von Ziffern. Die Ziffern werden auf Strichlinien nachgeschrieben, in Hohlziffern nachgespurt, in Rechenkästchen geschrieben, als Puzzle zusammengeklebt und die Ziffern aus Zeitschriften ausgeschnitten.

Aufbauend wird die Zuordnung Menge - Ziffer geübt.

Bei diesem Arbeitsmaterial werden verschiedene Arbeitstechniken genutzt, wie zum Beispiel Einkreisen, Verbinden, Anmalen, Aufkleben, Ankreuzen und Schreiben.

Die Kopiervorlagen sind klar und einfach strukturiert. Wiederholende Lerninhalte bieten eine gute Orientierung und vertiefen das Gelernte.

Die Arbeitsblätter enthalten keine Seitenzahlangaben, somit können Übungseinheiten individuell, je nach Leistungsstand der Schülerin oder des Schülers, genutzt werden.

Die bearbeiteten Arbeitsblätter können zusammen mit dem Deckblatt abgeheftet werden.

# Mein

## Ziffern-Mengenheft

0 bis 5

Name: \_\_\_\_\_

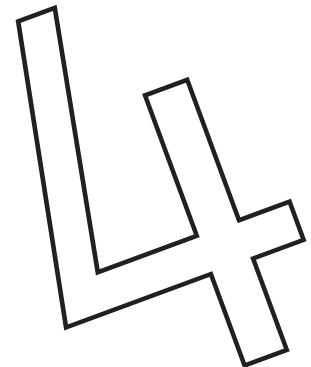
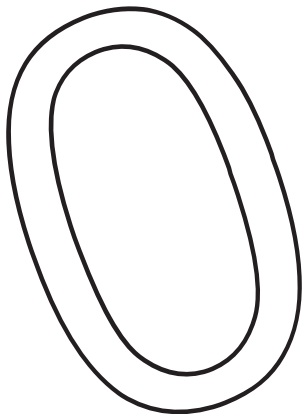
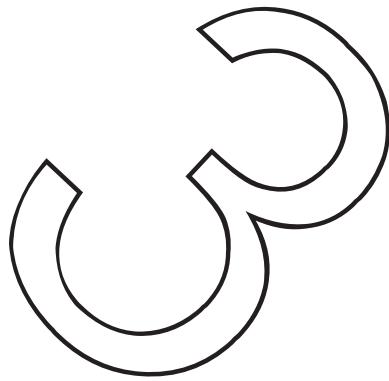
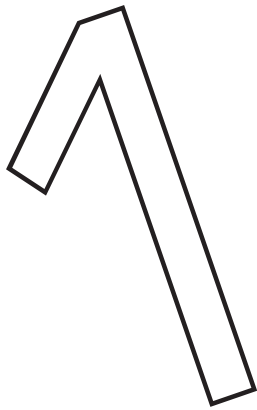

Name:

Datum:

Schreibe nach.

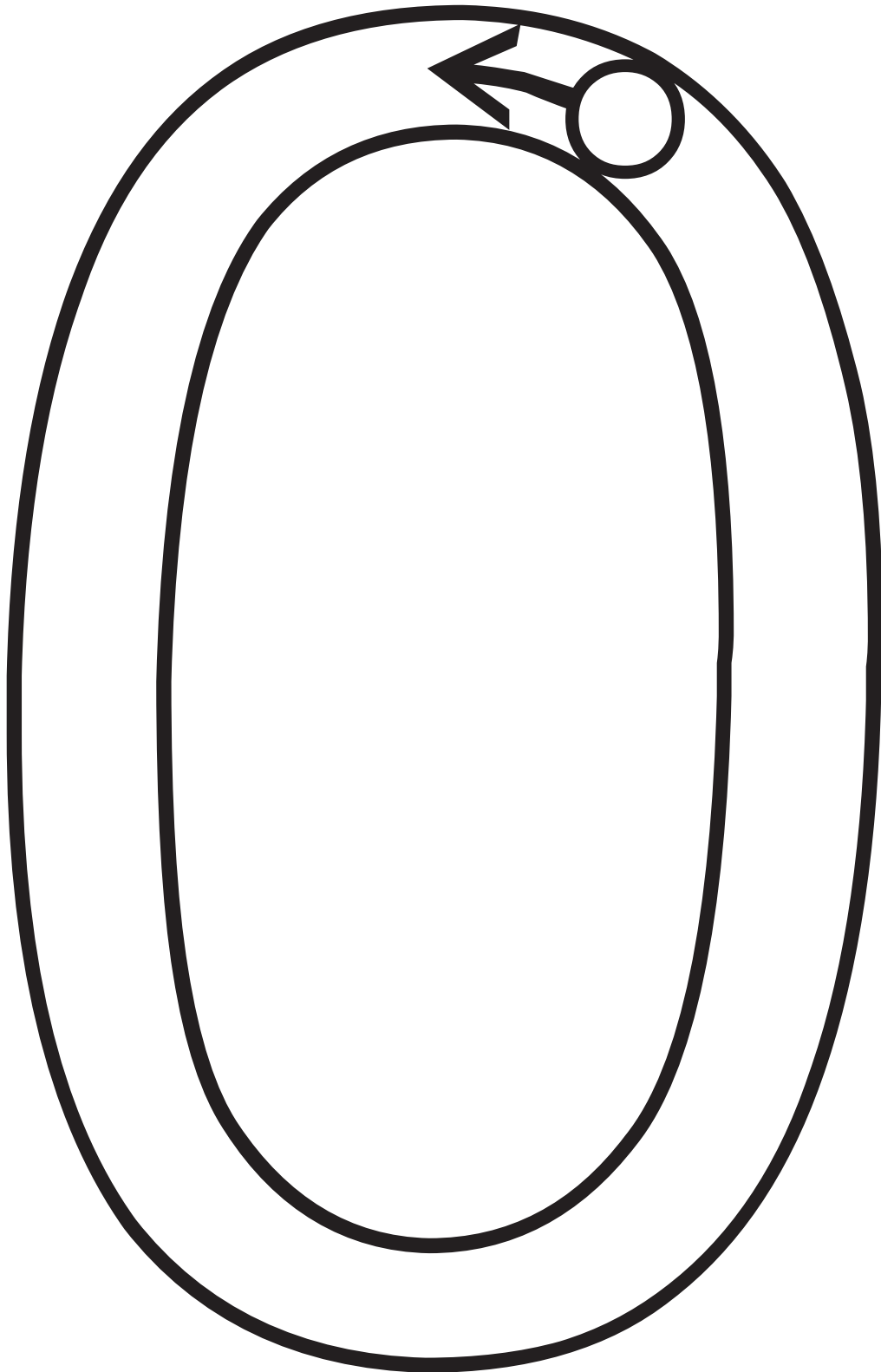
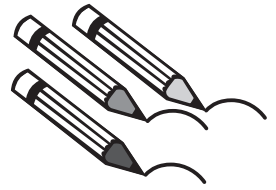

Name:

Datum:

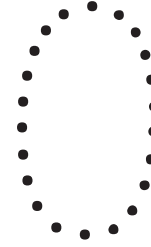
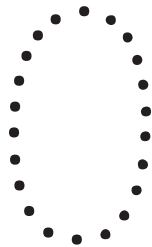
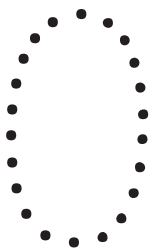
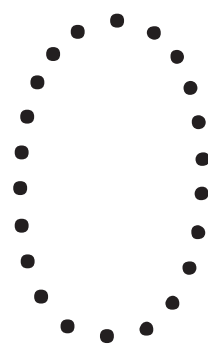
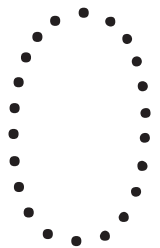
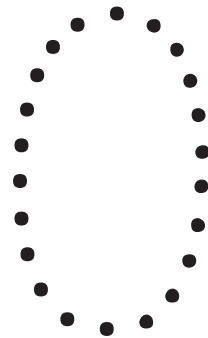
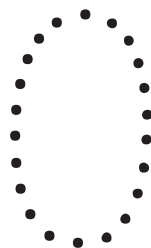
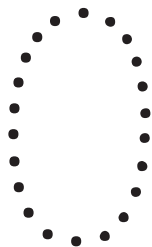
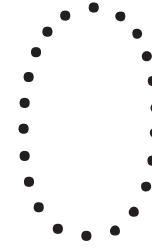
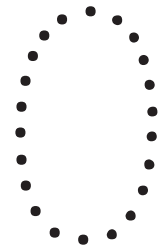
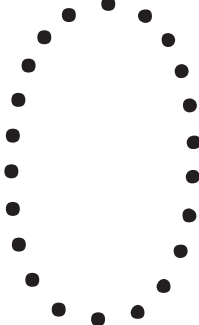
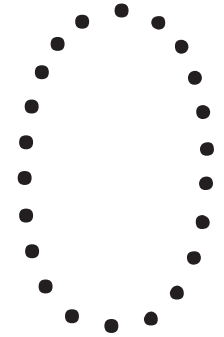
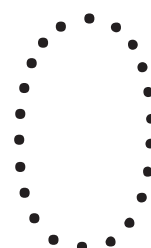
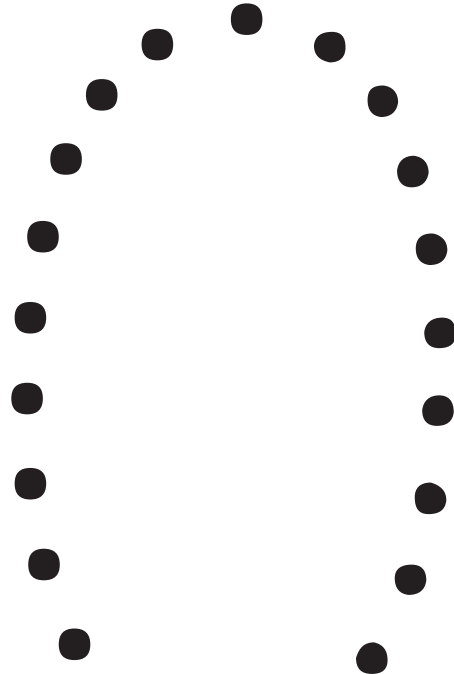
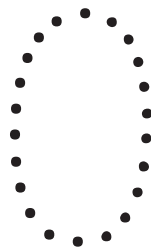
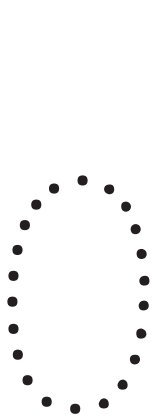
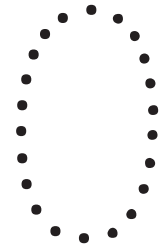
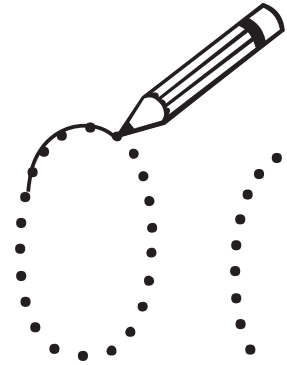
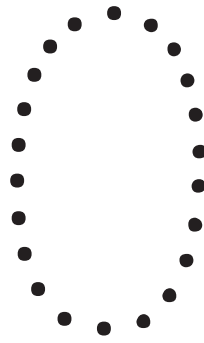
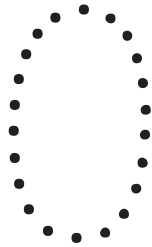
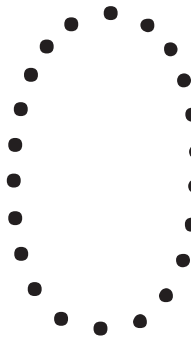

Name:

Datum:

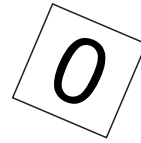
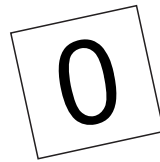
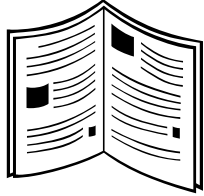





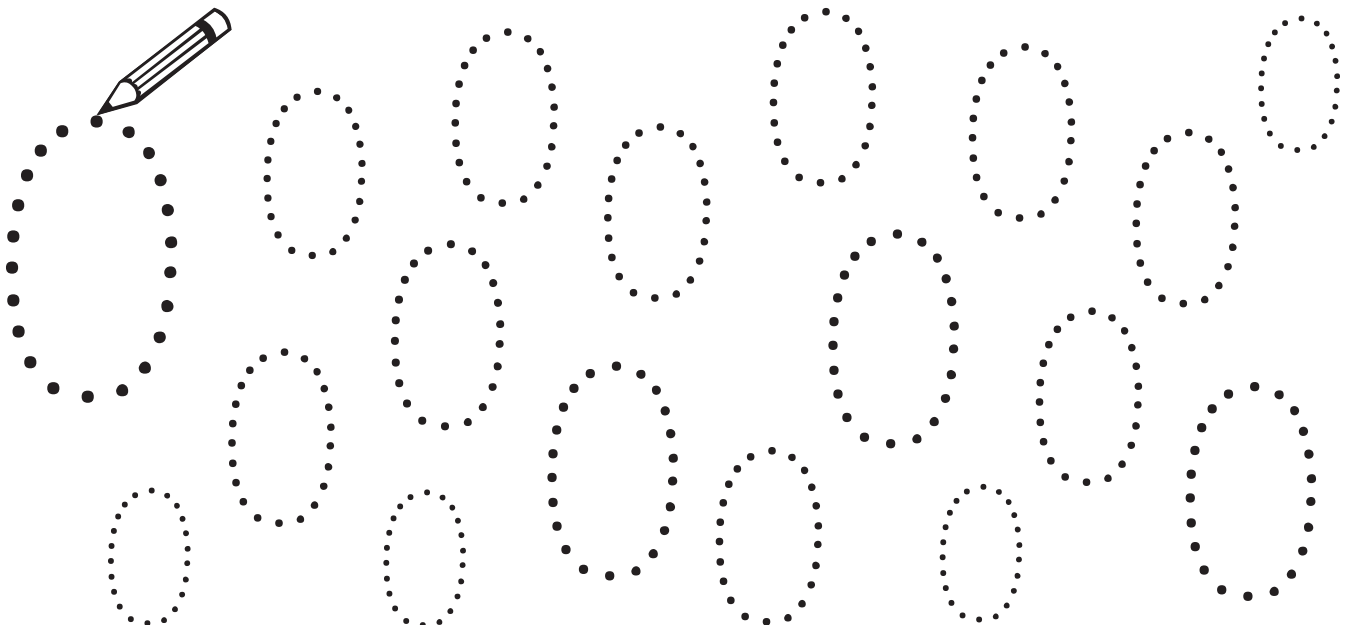
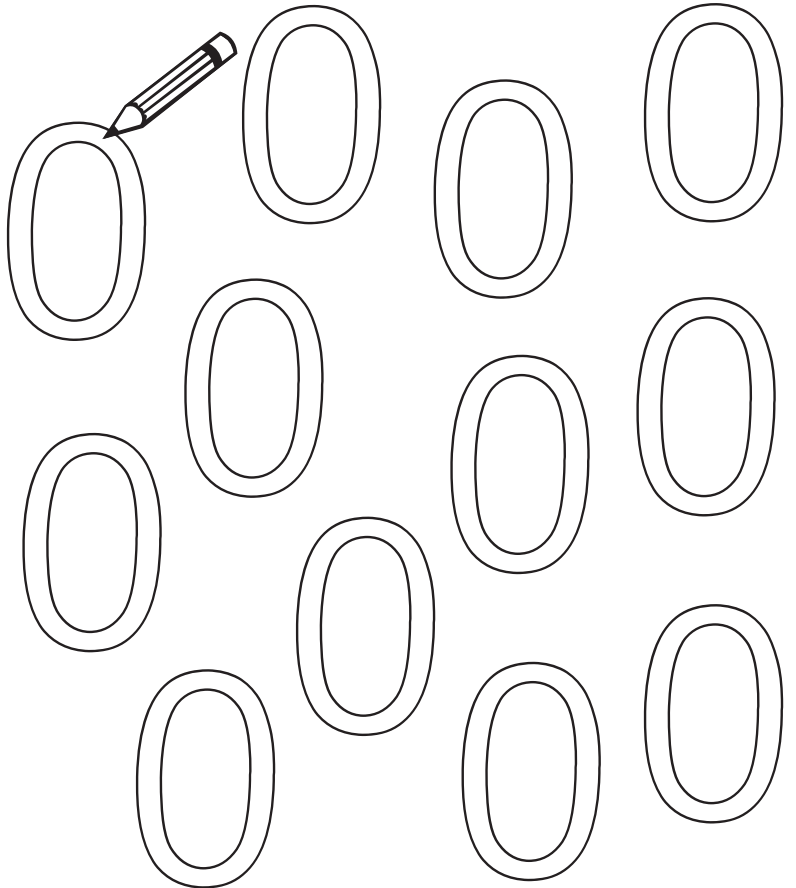
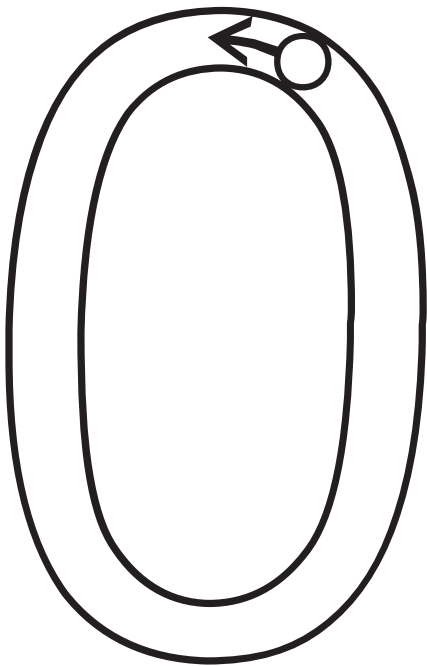



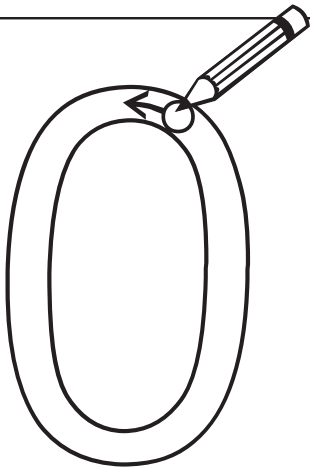
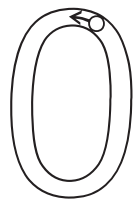
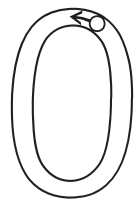
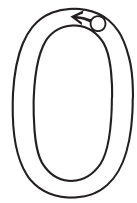

Name:

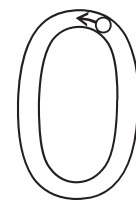
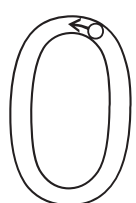
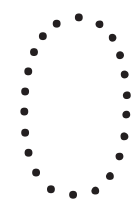
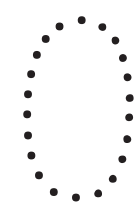
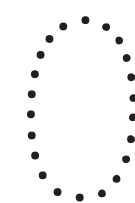
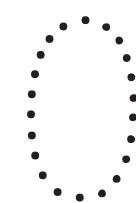
Datum:

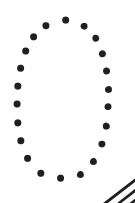

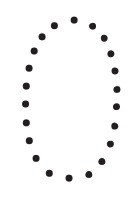
Name:

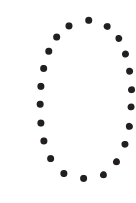
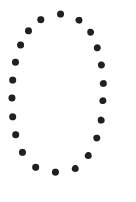
Datum:

	8	0	0	4	0	
1	0	3	2	0	0	5
0	0	0	1	3	0	2
0	2	0	7	0		

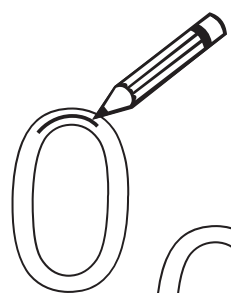

# SCHOOL-SCOUT.DE

Unterrichtsmaterialien in digitaler und in gedruckter Form

**Auszug aus:**

*Zahlenraum 0 bis 5 kennenlernen*

Das komplette Material finden Sie hier:

[School-Scout.de](https://www.school-scout.de)

